

## THE REFRACTOR REACTOR

The Refractor™ Reactor is a valuable tool for grazing angle studies of reactions on metal surfaces and on thin films on metal substrates. Samples can be heated to 400°C and pressurized up to 203 kPa (2 ATM). The Refractor™ Reactor incorporates two wedged windows to refract the beam to and from the sample. This unique design results in a compact reaction chamber and avoids the energy losses associated with the short plane mirrors typically employed in grazing angle accessories.

### APPLICATIONS

- ▶ Perfect for studying reaction on metal surfaces and on thin films on metal substrates.

### FEATURES

- ▶ 75° grazing incident angle for high sensitivity to films on metallic substrates.
- ▶ Incorporates two Supercharged™ ZnSe wedged windows to refract the beam to and from the sample.
- ▶ Ideal for samples up to 1"x2"x1/8".
- ▶ Heatable up to 500°C (under vacuum) for studying high temperature reactions.
- ▶ Operable at pressures from 13 mPa (10<sup>-4</sup> torr) to 203 kPa (2 ATM).
- ▶ Manufactured from chemically resistant 316 stainless steel.
- ▶ High efficiency.
- ▶ Designed for in-line use of a wire grid polarizer.



### INCLUDES

- ▶ Two ZnSe wedged windows.
- ▶ Alignment mirror.
- ▶ Mating hardware for the specified spectrometer.

### ORDERING INFORMATION

Refractor Reactor (24V).....CATALOG NO. RGR-XXX-3

### OPTIONS AND REPLACEMENT PARTS

Temperature Controller, 110V input, 24V output. Includes USB adapter.....	ATK-024-3
Temperature Controller, 220/240V input, 24V output (CE marked). Includes USB adapter.....	ATK-024-4
Supercharged™ ZnSe Wedged Window.....	RGA-001
Heater Assembly, 24V.....	RGR-HTR
Heater, 24V, 96W.....	HTRS-19
Wire Grid Polarizer.....	PWG-U1R
O-Ring Set, Viton.....	RGR-ORV
O-Ring Set, Kalrez.....	RGR-ORK

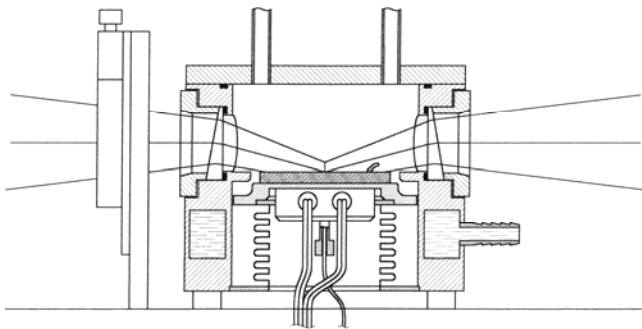

Figure 1. The Refractor Reactor.

The Reactor Refractor is a reaction chamber for in-line grazing incidence studies. It is ideal for recording spectra of thin films on metal substrates. The angle of incidence is fixed at 75 degrees and can accommodate samples up to 1"x2"x $\frac{1}{8}$ " thick. It can be heated up to 500°C under vacuum, evacuated to 13 mPa ( $10^{-4}$  torr), and pressurized up to 203 kPa (2 ATM) with the standard ZnSe windows. Excellent spectral contrast results.

Conventional in-line grazing incidence attachments have a significant drawback. The short plane mirrors employed do not totally intercept the beam of the spectrometer, resulting in a significant loss in optical throughput. In the Refractor, these losses do not occur, since the optical beam is deflected ( $15^\circ$ ) to and from the sample via wedged ( $10^\circ$ ) ZnSe windows.

The Refractor Reactor has two ports for flowing reactant over the sample, evacuating the sample, and pressurizing the sample with a reactant. Heating cartridges are imbedded below the sample and two thermocouples are supplied to measure the sample and heater temperatures. For precise temperature control, the heater and thermocouples should be connected to a Temperature Controller (Harrick's ATK-024-3 or ATK-024-4).

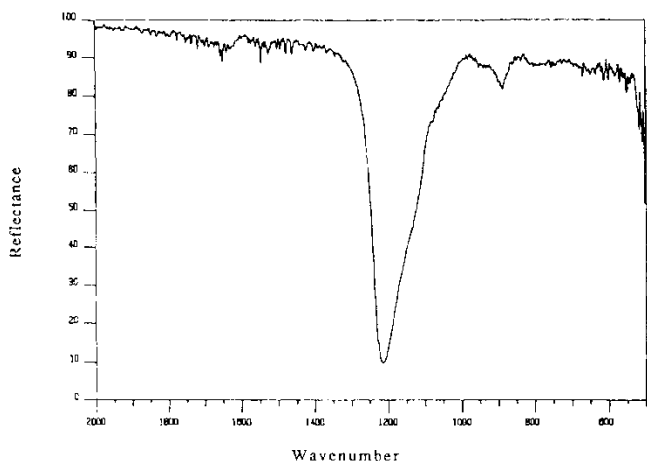

Figure 2. External Reflectance of SiO<sub>2</sub> on Aluminum.

Figure 2 shows the spectrum of a silicon dioxide film, approximately 500 Angstroms thick, on an aluminum substrate. In Figure 3, the spectrum of a 100 Angstrom layer

of silicone lubricant on an aluminum substrate is given. Here, an external wire-grid polarizer is used to generate P-polarized incident radiation.

The Refractor is supplied with all mounting hardware required to install it directly in the spectrometer and is compatible with most center focus FTIR instruments. Alignment is fast and simple.

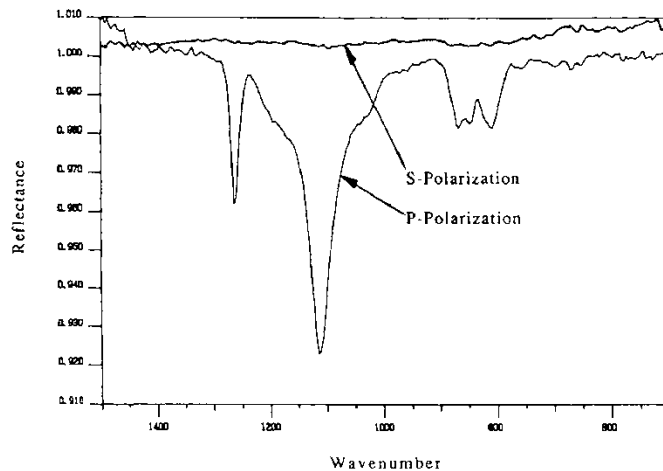

Figure 3. Grazing Angle Spectrum of Silicon Lubricant on Aluminum.