

COMPARISON OF ABSOLUTE REFLECTANCE METHODS: VW VS REFLECTANCE RELATIVE TO A STANDARD



Figure 1. The Variable Angle Reflectance Accessory with its Variable Angle Stage.

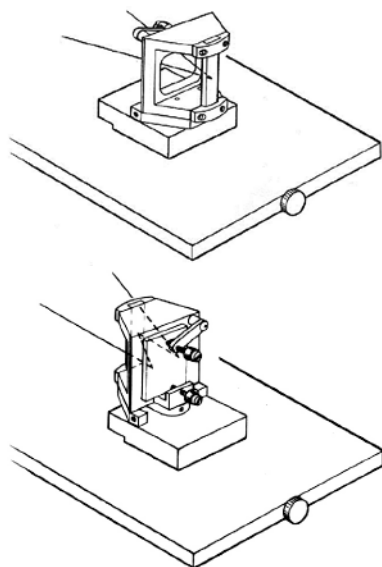

Figure 2. The 12° VW Absolute Reflection Stage, in its V (upper) and W (lower) configurations.

INTRODUCTION

Absolute reflectance is valuable in the optics and semiconductor industries. It can be used to characterize mirrors and other optical components in addition to coatings thereon. Absolute reflection measurements are necessary to determine the refractive indices and optical constants of materials.

Several different methods can be used to measure absolute reflectance. The two most common techniques are the VW method and comparison to a standard.

For the VW measurements, the background is collected with the stage in V mode and the sample collected in W mode and then the reflectance is calculated from the measurement. The VW offers the advantage of introducing no additional optics between the sample and reference measurement, thereby minimizing errors. For the measurement relative to a standard, an additional optic – the standard- is introduced. So the measurement depends on the refractive index of the reference.

The two methods are compared here to see if they give equivalent results.

EXPERIMENTAL

All spectra were collected on a commercial FT-IR spectrometer with the Harrick [Variable Angle Reflection Accessory](#) (see Figure 1) installed, with its VW absolute reflectance stage with a 12° incident angle (see Figure 2). Note that the reflectance depends on the incident angle and polarization, as well as the properties of the sample. A 12° incident angle is considered sufficiently low to avoid a significant contribution from the incident polarization so the measurements herein were done without a polarizer.

Two sets of measurements were recorded. For the VW measurements, the background was collected with the stage in V mode and the sample collected in W mode. The square root of the resulting spectrum was taken to extract the reflectance from the collected data. For the relative reflectance measurements, both the background and the sample were recorded with the stage in the V mode. The background was collected using a Ge reflectance reference (Harrick Scientific, P/N RRF-00J).

All spectra were signal averaged over 64 scans over the 4000 cm^{-1} to 400 cm^{-1} region. A background was collected before

COMPARISON OF ABSOLUTE REFLECTANCE METHODS: VW VS REFLECTANCE RELATIVE TO A STANDARD

every sample spectrum. The gain and optical velocity were adjusted to maximize the energy on the TGS detector while avoiding detector saturation.

Three materials were investigated: UV-grade fused silica (SiO_2), calcium fluoride (CaF_2) and cubic zirconia (ZrO_2),

RESULTS AND DISCUSSION

The absolute reflectance of SiO_2 , CaF_2 and cubic zirconia are shown in Figures 3 through 6 respectively. The data in red was collected using the VW method while that in blue was collected using the reflectance reference. In all cases, the two methods give virtually identical results.

The most significant difference in the spectra is the noise level. Not surprisingly, the noise level is lowest for cubic zirconia which has with the highest reflectance. The noise is slightly higher for the relative reflectance measurements of the two lower refractive index materials (SiO_2 and CaF_2 , $n=1.4$). This suggests studying lower refractive index materials by the VW method might be a better choice. Alternatively, using a reference with a refractive index more closely matched to that of the sample might also reduce the noise. The refractive index of Ge

is 4.0, which is closest to that of cubic zirconia (~ 2.15).

CONCLUSION

Both the VW and the relative reflectance absolute reflectance methods give comparable results in terms of the measured reflectance.

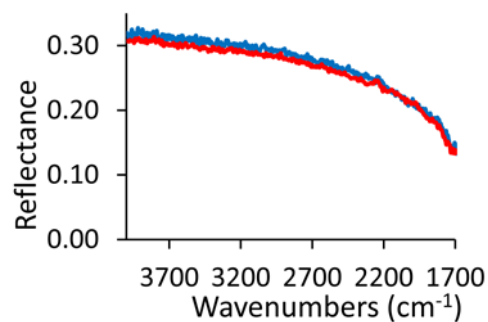

Figure 3. Absolute Reflectance Spectrum of SiO_2 measured using the VW method (red) and relative to a reference (blue).

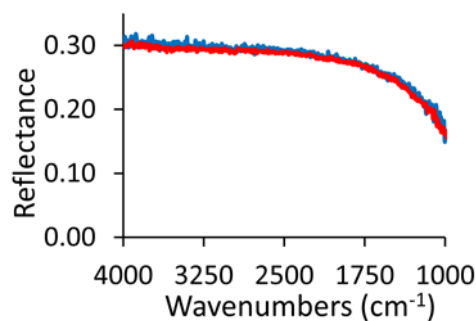

Figure 4. Absolute reflectance of CaF_2 measured using the VW method (red) and relative to a reference (blue).

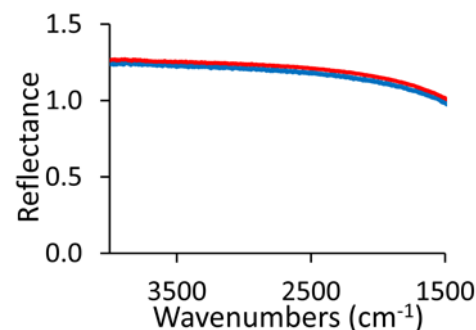

Figure 5. Absolute reflectance of cubic zirconia measured using the VW method (red) and relative to a reference (blue).



HARRICK SCIENTIFIC PRODUCTS

141 Tompkins Ave., 2nd floor • PO Box 277 • Pleasantville, NY 10570

www.harricksci.com • E-mail: info@harricksci.com

Phone (international): 914-747-7202 • Phone (in USA): 800-248-3847 • Fax: 914-747-7209