

## LOW VOLUME HIGH TEMPERATURE REACTION CHAMBER FOR THE PRAYING MANTIS

Diffuse reflectance is ideal for detecting changes at the surfaces of powders with high surface areas. This Low Volume High Temperature Reaction Chamber is well suited for studying heterogeneous catalysis, gas-solid interactions, photochemical reactions, and oxidation mechanisms under controlled temperatures and pressures. It is designed for operation with our [Praying Mantis](#) diffuse reflection accessory and our [Temperature Controller](#). The low interior volume, low dead volume and flow configuration are intended to optimize downstream analysis of the reacted gases.

### APPLICATIONS

- ▶ Excellent for analysis of catalytic reactions, gas-solid interactions, photochemical reactions and oxidation studies.
- ▶ Diffuse reflection measurements under controlled temperatures and pressures.

### FEATURES

- ▶ Designed for operation from high vacuum (133  $\mu$ Pa or  $10^{-6}$  torr) to 133 kPa (1 ktorr) with KBr windows or 1.5 MPa (11.2 ktorr) with ZnSe or SiO<sub>2</sub> windows.
- ▶ Achieves temperatures up to 550° C under vacuum and 465° C to 525° C typically with gas flow or pressurization. Maximum achievable temperature varies depending on the experimental setup.
- ▶ Two gas/vacuum ports provided, with 1/16" Swagelok fittings:
  - ▶ Inlet for gas introduction
  - ▶ Outlet below the sample which pulls the gas through the sample for downstream analysis of the reacted gas.
  - ▶ Internal pre-heating of the inflow and outflow.
- ▶ Total internal volume, including the 6" gas inlet and outlet tubes: 3.0 mL.
- ▶ Two K-type thermocouples for monitoring the heater temperature and the sample cup temperature.
- ▶ Cooling conduits with 1/4" barbed fittings to keep the exterior of the cell cool during high temperature operation.
- ▶ Low-voltage heating cartridge.
- ▶ Made of chemically resistant 316 stainless steel.
- ▶ Integral vacuum chamber vacuum chamber 1/4" VCO fitting to improve thermal efficiency at elevated temperatures.
- ▶ Alternative window assemblies available for microspectroscopy applications, including Raman.
- ▶ Optional Silcotek/Restek coatings available for superior inertness and corrosion resistance.
- ▶ Optional cooling cartridge for moderate cooling or heating.

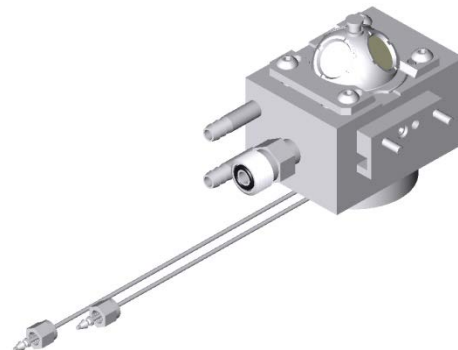

## ELECTROCHEMICAL-READY ADAPTERS FOR THE HIGH TEMPERATURE REACTION CHAMBERS

Because diffuse reflectance and Raman spectroscopy are extremely sensitive to changes on the surfaces, they are well suited to investigate spectroelectrochemical changes on samples such as solar cells, solid fuel cells, semiconductors, electrodes, catalysts, etc. These electrochemical-ready adapters are ideal for characterizing these types of materials under controlled environmental conditions during exposure to applied current or voltage.

### APPLICATIONS

- ▶ In-situ electrochemistry measurements.
- ▶ Studies of particles immobilized on electrodes and other surfaces.
- ▶ Spectroscopy of electrochemically induced polymerizations.
- ▶ Monitoring optical changes during redox processes on inorganic semiconductor electrodes.
- ▶ Scrutinizing the effect of trap states on the optical and electronic properties of photoelectrodes and semiconductors.
- ▶ Kinetic studies of electrode processes under various electrochemical conditions, including electrochemical impedance spectroscopy and cyclic voltammetry spectroscopy.
- ▶ Spectroelectrochemical investigations of induced alterations to the electronic structure.
- ▶ Operando studies of Stark tuning rates.

### FEATURES

- ▶ Aperture size for accessing the sample to connect the electrodes:
  - ▶ 25-mm for the diffuse reflectance chamber
  - ▶ 18.5 mm aperture for the Raman microscopy chamber.
- ▶ 1/16" diameter tube for electrode feed-through.
- ▶ Accommodates samples up to 11 mm in diameter.
- ▶ 1/8" Swagelok fittings to adapt to electrode feed-throughs.
- ▶ Two and three electrode-ready models available.
- ▶ Made from chemically-inert 316 stainless steel.
- ▶ Compatible with the [Praying Mantis High Temperature Reaction Chamber](#) and [Raman High Temperature Reaction Chamber](#).

### INCLUDES

- ▶ Sample support (specify sample thickness when ordering)
- ▶ Requires an electrical insulator on the bottom of the sample or between the sample and its support (thin ceramic film recommended).

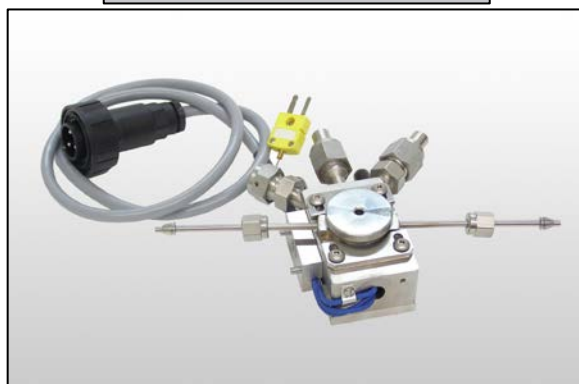
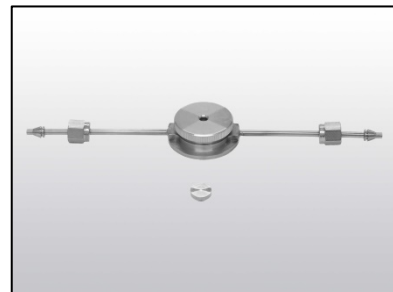
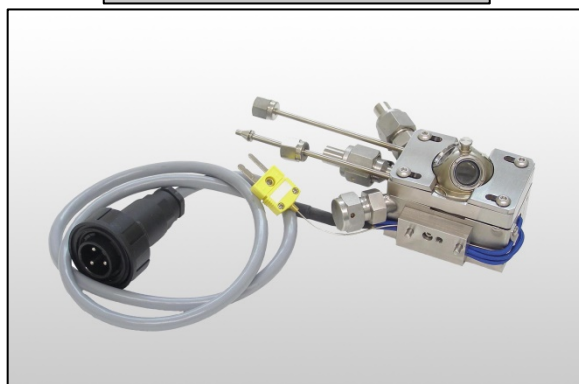
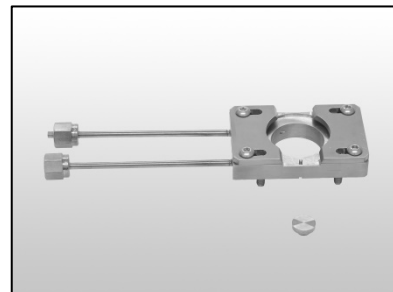

## HIGH TEMPERATURE GAS CELL

Gas cells are ideal for examining gases and gaseous mixtures for static or flow environments. This high temperature gas cell is excellent for both room temperature studies and heated measurements, up to 500°C and up to pressures of 303 kPa.

### APPLICATIONS

- ▶ Well-suited for spectroscopic studies of gases and vapors from room temperature to 500°C (under vacuum) and up to 303 kPa (2.2 ktorr).
- ▶ Adaptable for evolved gas analysis (EGA) in combination with thermogravimetric analysis for TGA-EGA-FTIR.
- ▶ Ideal for deposition studies.

### FEATURES

- ▶ 10 cm pathlength.
- ▶ Heatable to 500°C (under vacuum).
- ▶ Beam conforming interior maximizes pathlength to volume ratio.
- ▶ Cell volume: 17 ml.
- ▶ All metal parts in contact with the gas are made from chemically resistant 316 stainless steel.
- ▶ Thermocouple and heaters.
- ▶ 25 x 2 mm windows provide a 20-mm diameter clear entrance and exit apertures.
- ▶ Maximum operating pressure: 303 kPa (2.2 ktorr).
- ▶ Kalrez o-rings.
- ▶ Heat sinks and heat shield enclosure.
- ▶ Two ports allow both static and flow-through applications.
- ▶ Compatible with the Harrick Temperature Controller.

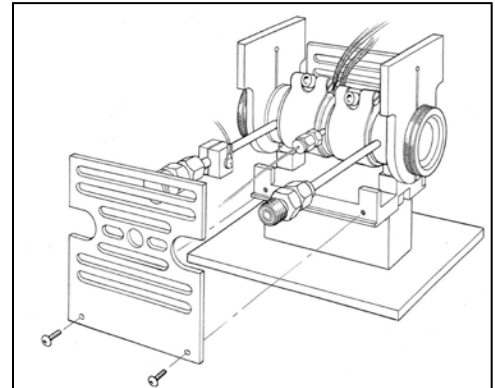

### INCLUDES

- ▶ Kalrez 7075 o-rings
- ▶ 24V, 200W band heaters.
- ▶ K-type thermocouple.
- ▶ Two 1/4" swagelok fittings.
- ▶ Two ZnSe windows.
- ▶ Mating hardware for the specified spectrometer.

## 4X Beam Condensers

Harrick Scientific can provide 4X beam condensers for analyzing very small quantities of sample using infrared spectroscopy. Typically these beam condensers can be converted from transmission to ATR by simply re-aligning the mirrors. As transmission units, pellets as small as 3mm in diameter can be examined and small amounts of liquids can be contained in liquid cells with 6mm diameter windows. For ATR spectroscopy, beam condensers can provide for surface analysis of many small samples.

### APPLICATIONS

- ▶ Transmission and ATR studies of small quantities of liquids, pastes, and soft or flexible solids.

### SUGGESTED FEATURES

- ▶ Variable incident angle: 30° to 60°.
- ▶ Includes a dial for setting the angle.
- ▶ Generates a spot 1/4 of the normal sample beam size for more efficient irradiation of small samples.
- ▶ Maximizes signal throughput while minimizing spectral distortions.
- ▶ Pellet holder for transmission measurements.
- ▶ Utilizes 10mm or 25mm long crystals for ATR measurements.
- ▶ Easily converts from ATR to transmission.
- ▶ Specially designed ATR pressure plates float, eliminating unnecessary strain on the ATR crystal.
- ▶ Easy mounting to the specified FT-IR spectrometer.

### SAMPLE APPLICATIONS

- ▶ Robert J. Jakobsen and R. Michael Gendreau, "Blood Plasma/Implant Interfaces: FT-IR Studies of Adsorption on Polyethylene and Heparin-Treated Polyethylene Surfaces", *Artificial Organs*, 2(2), 183 (1978).
- ▶ K. Knutson and D. J. Lyman, "The influence of sterilization on bulk and surface morphologies of copolyether-urethane-ureas", *SPIE Proc. of the 1981 Intl. Conf. on FTIR*, 298, 172 (1981).
- ▶ K. Knutson and D. J. Lyman, "Morphology of Block Copolyurethanes. II. FTIR and ESCA Techniques for Studying Surface Morphology", *Biomed. and Dent. Appl. of Polymers*, Plenum (NY), 173 (1981).
- ▶ K. Knutson and D. J. Lyman, "The Effect of Polyether Segment Molecular Weight on the Bulk and Surface Morphologies of Copolyether-Urethane-Ureas", *Adv. in Chem.: Biomat.*, 199, 109 (1982).
- ▶ Michele Derrick, "Fourier Transform Infrared Spectral Analysis of Natural Resins Used in Furniture Finishes", *J. Am. Inst. for Conservation*, 28(1), 43 (1989).
- ▶ Senja V. Compton and Phil Stout, "Qualitative Analysis of Thin Coatings on Lenses: A Comparison of Infrared Spectroscopic Techniques", *Am. Lab.*, May, 36N (1993).
- ▶ S.A. Johnson, N.-J. Pham, V. J. Novick, and V. A. Maroni, "Application of Surface-Enhanced Infrared Absorption Spectroscopy as a Sensor for Volatile Organic Compounds", *Appl. Spectros.*, 51(9), 532 (1997).
- ▶ T. R. Jensen, R. P. Van Duyne, S. A. Johnson, and V. A. Maroni, "Surface-Enhanced Infrared Spectroscopy: A Comparison of Metal Island Films with Discrete and Nondiscrete Surface Plasmons", *Appl. Spectros.*, 54(3), 571 (2000).

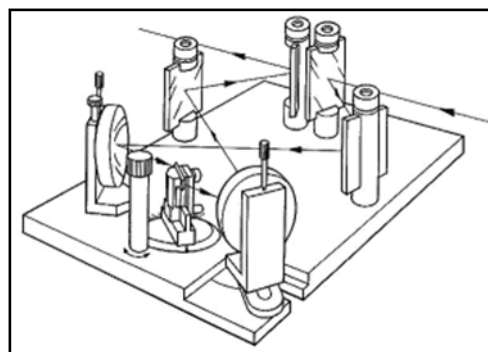
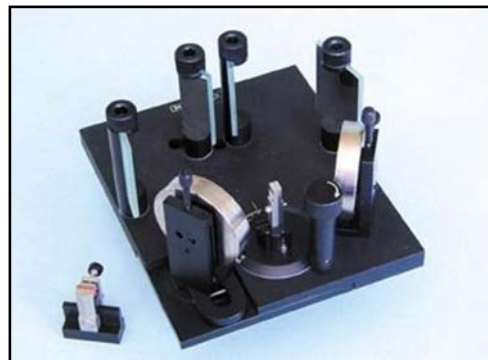

## 6X Beam Condensers

Our custom 6X beam condensers are especially suitable for examining very small quantities of samples. These beam condensers typically use 90° off-axis ellipsoids to focus the beam onto the sample. They provide sufficient working space for such accessories as high-pressure diamond cells.

### APPLICATIONS

- ▶ Transmission and ATR studies of small quantities of liquids, pastes, and soft or flexible solids.
- ▶ Ideal for use with high-pressure diamond cells.

### SUGGESTED FEATURES

- ▶ Easily converts from ATR to transmission to accommodate a variety of experiments.
- ▶ A spot 16% of the normal sample beam size, for more efficient irradiation of small samples.
- ▶ Fixed angle transmission beam condenser, providing a working space of approximately 40mm. Features large ellipsoids.
- ▶ Recommended for use with high-pressure diamond cells.
- ▶ 3-mm diameter pellet holder for transmission measurements.
- ▶ Easy mounting to the specified spectrometer.

### SAMPLE APPLICATIONS

- ▶ Brian Caddy, ed., *Forensic examination of glass and paint: analysis and interpretation*, Taylor and Francis, 221 (2001).
- ▶ M. I. Eremets, ed., *High pressure experimental methods*, Oxford University Press, 345 (2002).

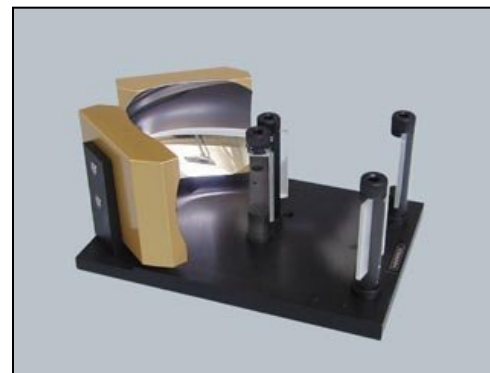

## MultiLoop-MIR™ FTIR Fiber Optic Probe: Spectroscopy Outside the Box

This MultiLoop-MIR system is perfect for analyzing liquids, pastes, and soft solids outside of the FTIR spectrometer sample compartment. It is used in conjunction with the Harrick [FiberMate2](#) or other fiber optic coupler and includes two fiber probes with a set of ten ATR loop tips. This combination is designed for spectral data collection across the entire mid-infrared region. To analyze a sample, simply dip the ATR loop tip into the sample or press it gently against the sample. The tips are easily replaced when needed.

### APPLICATIONS

- ▶ Multiple reflection ATR (internal reflectance) accessory.
- ▶ In-situ analysis of a wide variety of liquids, pastes, and soft solids.
- ▶ Quantitative and qualitative analysis.

### FEATURES

- ▶ Multiple reflection ATR sampling outside the FTIR spectrometer.
- ▶ Effectively provides two reflections when compared to ATR with ZnSe at 45°.
- ▶ Wavelength range: 6500 cm<sup>-1</sup> to 600 cm<sup>-1</sup>:
  - ▶ Chalcogenide glass probe for use from 6500 to 1700 cm<sup>-1</sup>.
  - ▶ Polycrystalline Silver halide probe for use from 2000 to 600 cm<sup>-1</sup>.
- ▶ Sampling loop tips designed for the full spectral range of 6500 to 600 cm<sup>-1</sup>:
  - ▶ Dip into or press against the sample.
  - ▶ Leak-free for analysis of liquids.
  - ▶ Readily replaceable.
  - ▶ Made from silver halide fiber material.
- ▶ Easy to use.
- ▶ Suitable for aqueous solutions and organic samples.
- ▶ Standard probe length of 1meter allows sampling outside the spectrometer sample compartment.
- ▶ Designed for use with DTGS or MCT detectors.
- ▶ SMA connectors for easy connection to fiber optic couplers.
- ▶ Operable from room temperature to 100°C.
- ▶ Use with the Harrick FiberMate2™ fiber optic coupler for purged operation in most FT-IR spectrometers.

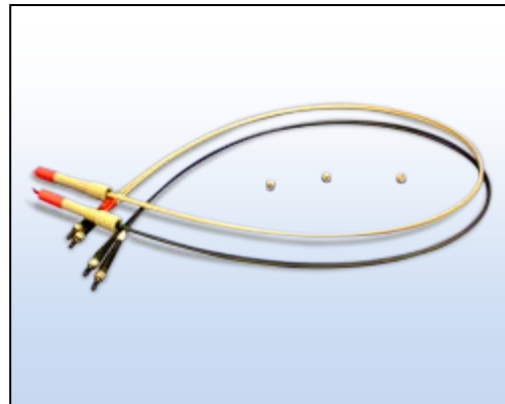

### SAMPLE APPLICATIONS

Below are some sample applications. All spectra were taken using the FiberMate2™ coupler in an FTIR spectrometer with a DTGS detector set for 64 scans at an 8cm<sup>-1</sup> resolution. The chalcogenide probe was used for 4000cm<sup>-1</sup> to 1520cm<sup>-1</sup> and the silver halide probe for the 1530cm<sup>-1</sup> to 600cm<sup>-1</sup> region. Both spectra were baseline corrected and merged to show the full spectral range.

- ▶ Figure 1. ATR Spectra of Children's Liquid Pain-Relievers Motrin (black) and Tylenol (blue).

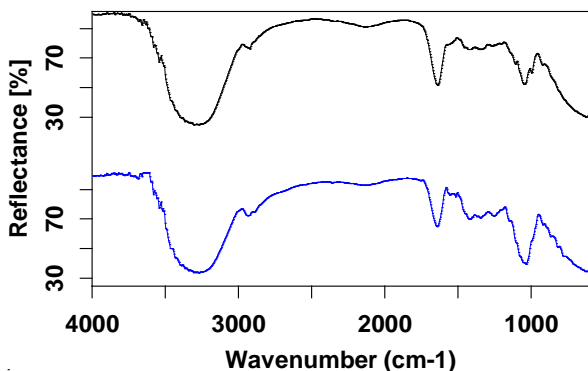

- ▶ Figure 2. ATR Spectrum of Kouros White Wine.

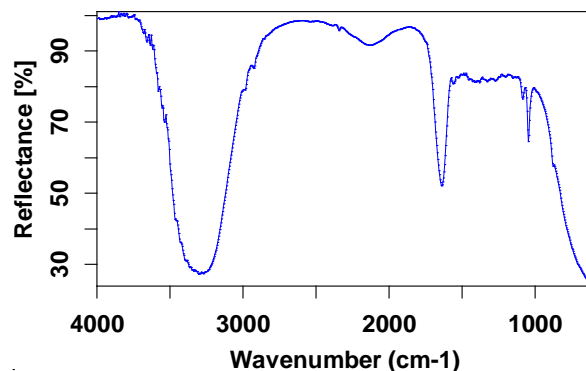

## BoostIR™

The BoostIR™ is a specifically designed for non-contact multiple external reflection FTIR spectroscopy. Samples as small as 7 mm (or as large as 120 mm) in diameter can be accommodated. The BoostIR™ provides approximately thirteen reflections at a 45° incident angle. Compared to traditional 75° grazing angle specular reflection techniques, the BoostIR™ provides twice the sensitivity yet requires significantly less sample real estate. As such, the BoostIR™ is uniquely suited for the analysis of small samples of thin films on specularly reflecting metal substrates where contact would damage either film or substrate.

### APPLICATIONS

- ▶ Excellent for recording spectra of small samples of thin films on specularly reflecting metal substrates

### FEATURES

- ▶ 45° incident angle multiple specular reflection accessory.
- ▶ Provides twice the sensitivity of traditional 75° grazing angle specular reflection techniques.
- ▶ Convenient horizontal sampling stage.
- ▶ Accommodates samples from 7 mm in diameter to 120 mm.
- ▶ Integrated wire grid polarizer.
- ▶ Includes alignment mirror for quick set-up.
- ▶ Easily mounts to the specified spectrometer.
- ▶ Recommended for use spectrometers equipped with an MCT detector.



### SAMPLE APPLICATIONS

Below are some sample applications of the BoostIR™. All spectra were taken using a wire grid polarizer set for perpendicular polarization. A commercially available FTIR spectrometer equipped with an MCT detector was employed. Spectra were signal averaged over 64 co-added scans and taken with 4 cm<sup>-1</sup> resolution.

- ▶ Figure 1. The spectra of a thin film of SiO<sub>2</sub> on an aluminum substrate acquired via 45° single reflection (blue), 75° single reflection (red), and the BoostIR™ (black). The negative baseline for the BoostIR™ spectrum is due to the slightly higher reflectivity of the sample than the reference, magnified by the multiple reflections.

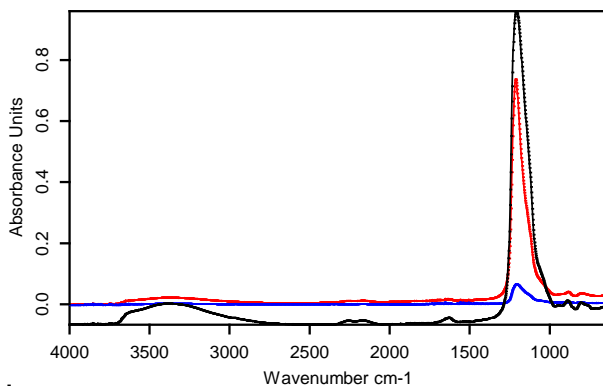

- ▶ Figure 2. The spectra of a 100Å coating of MgF<sub>2</sub> on gold acquired via 45° single reflection (blue), 75° single reflection (red), and the BoostIR™ (black).

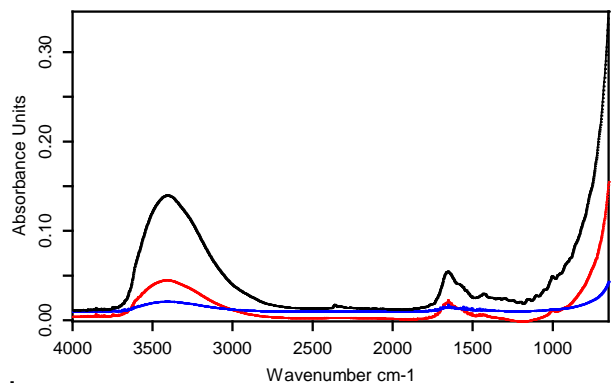

## Customized Horizons

Harrick's [Horizon](#) is a multiple reflection ATR accessory with a convenient horizontal sampling surface. The mounted ATR crystals are readily removable from the Horizonmirror assembly and have virtually unlimited space around them, making this an ideal platform for custom ATR applications. The Horizon crystal holders can be customized to meet your sampling needs.

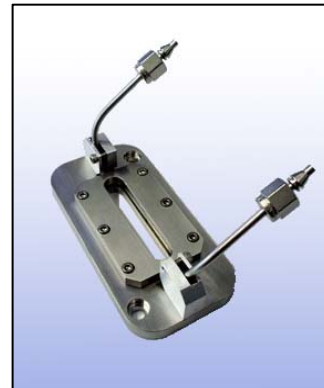

### APPLICATIONS

- ▶ Special crystal holders to accommodate crystals 0.25 mm to 0.5 mm thick for studies of chemically modified Si surfaces.
- ▶ Crystal holders designed for rapid crystal exchange during studies of coated or modified crystal surfaces.
- ▶ Large volume liquid cells for examining the residues of evaporated liquids.
- ▶ Low volume laminar flow cells.
- ▶ Electrically isolated liquid cells for electrochemical studies.
- ▶ Custom liquid cells for real-time spectroscopy of UV-induced chemical reactions.
- ▶ Special liquid cells for simultaneous light microscopy and infrared spectroscopy.
- ▶ Low pressure cells.

### SUGGESTED FEATURES

- ▶ Top loading with an unobstructed, horizontal sampling surface (HATR).
- ▶ Thirteen reflections from the sample with the standard 50x10x2mm SPT 45° ATR crystal.
- ▶ Readily exchangeable and customizable sampling plates and liquid cell adapters.
- ▶ Gasket-sealed trough for measurements of liquids and pastes with user replaceable ATR crystal.
- ▶ Rapid sample and crystal exchange without interrupting the purge.
- ▶ PermaPurge™ permits crystal exchange with minimal interrupting of the purge of the FT-IR system.
- ▶ Wire grid polarizer available separately.
- ▶ Easy mounting to the specified spectrometer.

### SAMPLE APPLICATIONS

- ▶ P. A. Sucki, K. J. Siedlecki, R. J. Palmer, JR., D. C. White and G. G. Geesey, "Combined Light Microscopy and Attenuated Total Reflection Fourier Transform Infrared Spectroscopy for Integration of Biofilm Structure, Distribution, and Chemistry at Solid-Liquid Interfaces", *Applied and Environmental Microbiology*, 63(11), 4600 (1997).
- ▶ ShilpaDubey, Keijing Li, Harish Bhandari, Zheng Hu, C. Heath Turner, and Tonya M. Klein, "In situ ATR - FTIR spectroscopy of Hf(IV) tertbutoxide adsorption on Si and Ge", *Mater. Res. Soc. Symp. Proc.* 917, 0917-E09-03 (2006).



## Disk Checker

Our custom-built Disk Checkers are ideal for inspecting magnetic disks, hard drive disks and wafers for lubrication and contamination. These Disk Checkers can be equipped with a stage on which the disks simply rest for simple inspection of the disks or an  $r-\theta$  stage for scanning the entire surface of the disk.

### APPLICATIONS

- ▶ Unsurpassed for examining lubricating films and surface contaminants on large magnetic disks.

### SUGGESTED FEATURES

- ▶ Unobstructed, horizontal sampling surface accommodates a wide range of disk sizes.
- ▶ Fixed  $75^\circ$  incident angle and built-in polarizer for optimum spectral sensitivity.
- ▶ Translation stage for systematic surface characterization or a fixed stage for easy sample loading.
- ▶ PermaPurge™ for minimal interruption of the purge when changing samples.
- ▶ Disk holders for 20mm, 25mm, and 2.5" i.d. disks.
- ▶ Custom holders available to accommodate various sample sizes.
- ▶ Alignment fixture for optimal performance.
- ▶ Mounts easily to the specified spectrometer.

### SAMPLE APPLICATIONS

- ▶ Frederik T. Walder, D. Warren Vidrine, and George Hansen, "The Analysis of Lubricants on Magnetic Disks by Fourier Transform Infrared Spectroscopy", *Appl. Spectros.*, 38 (6), 782 (1984).



## Emission Accessory

Harrick's Emission Accessory is a powerful tool for examining vibrational spectra of surface species. Custom manufactured to attach to any spectrometer with an emission port.

### APPLICATIONS

- ▶ Powerful tool for studying vibrational spectra of surface species.
- ▶ Enables emission measurements of samples under controlled temperatures and pressures.

### FEATURES

- ▶ Collects the emittance over a large angular distribution.
- ▶ Permits sampling of small areas.
- ▶ Use with either a room temperature (DTGS) or cooled (MCT) detector.
- ▶ PermaPurge™ for minimal interruption of the purge when changing samples.
- ▶ Translation stage for easy sample positioning.
- ▶ Samples are secured in enclosable chamber:
  - ▶ Designed for operation from high vacuum (133  $\mu$ Pa or  $10^{-6}$  torr) to 133 kPa (1 k torr) and at temperatures up to 910°C (under vacuum).
  - ▶ Three inlet/outlet ports provided for evacuating the cell and introducing gases.
  - ▶ Made of chemically resistant 316 stainless steel.
  - ▶ Readily adapted for operation up to 3.44MPa (25.8 k torr) with an optional high-pressure dome.
  - ▶ Optional Silcotek/Restek coatings available for superior inertness and corrosion resistance.
  - ▶ Optional cooling cartridge available for moderate cooling or heating with a chiller or recirculator.
- ▶ Compatible with any spectrometer with an emission port.
- ▶ Readily mounts to the emission port of the specified spectrometer.
- ▶ Compatible with the Harrick [Temperature Controller](#).

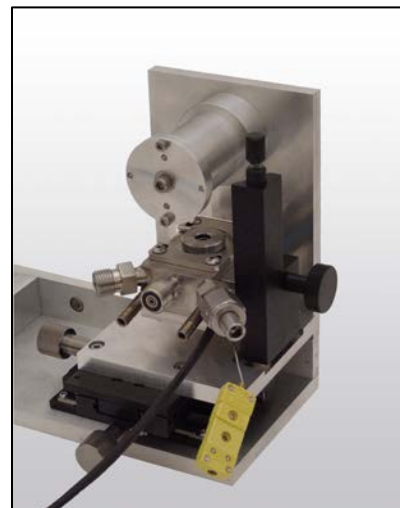

### SAMPLE APPLICATIONS

- ▶ M. Handke and N.J. Harrick, "A New Accessory for Infrared Emission Spectroscopy Measurements", *Appl. Spectros.*, 40(3), 401 (1986).
- ▶ J. A. McGuire, B. Wangmaneerat, T.M. Niemczyk, and D.M. Haaland, "Modifications to a Commercial Emission Apparatus to Permit Quantitative Applications", *Appl. Spectros.*, 46(1), 178 (1992).
- ▶ On the right is a sample application of the Emission Accessory, comparing the infrared emission of a 6  $\mu$ m thick Mylar film to its ATR spectrum. The emission spectrum was measured on an FT-IR with an MCT detector with the Emission Accessory fitted to the emission port with the sample was at room temperature. The spectrum was collected with 64 scans and 4  $\text{cm}^{-1}$  resolution. The ATR spectrum was taken using the Harrick FastIR on an FTIR with a DTGS detector. The spectrum was a result of 64 averaged scans with a resolution of 4  $\text{cm}^{-1}$ . The emission spectrum is shown in red and the ATR spectrum is shown in blue.
- ▶ Also see our applications notes on:
  - ▶ [The Analysis of Water Content of Clay](#)
  - ▶ [The Study of Germanium Oxide Formation](#)

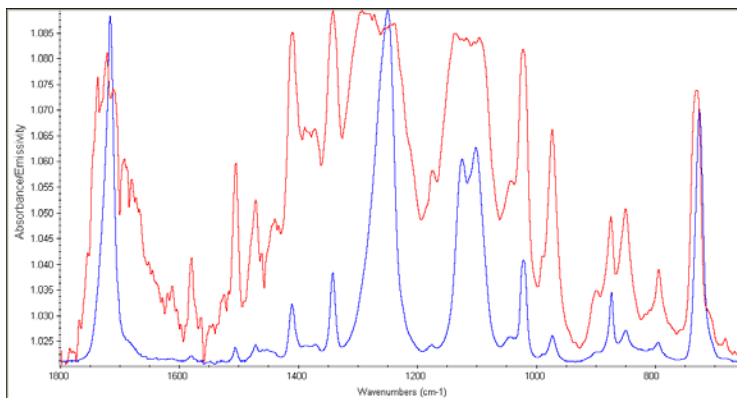

## FastIR™ Reactor

Harrick Scientific can supply single reflection ATR chambers for examining liquids undergoing reactions at various temperatures and pressures. These high performance chambers are usually equipped with a crystal mounted on its side to prevent spectral interference from precipitates.

### APPLICATIONS

- ▶ Useful for real-time monitoring of liquid reactants and/or products via single reflection ATR.

### SUGGESTED FEATURES

- ▶ 45° single reflection ATR accessory.
- ▶ Chemically resistant 316 stainless steel reaction vessel.
- ▶ Heatable to 250°C using the two incorporated cartridge heaters.
- ▶ K-type thermocouple measures the sample temperature.
- ▶ Pressurizable to 800psi with a ZnSe ATR crystal.
- ▶ ATR crystal materials available include ZnSe and Si.
- ▶ Unique side-mounted 45° prism minimizes interference from precipitates.
- ▶ Highly efficiency.
- ▶ PermaPurge™ to maintain the system purge without closing the sample compartment cover.
- ▶ Straightforward to align.
- ▶ Compatible with Parr MicroReactor™ reaction vessel heads and stirrers.
- ▶ Readily interfaces to the specified spectrometer.

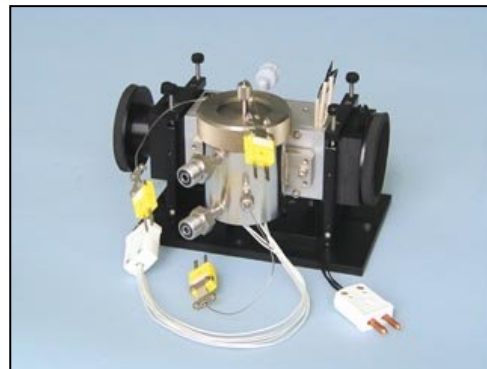

## Specialized Seagulls

The Seagull is one of the most versatile reflectance accessories on the market. Offering both variable angle specular reflectance and ATR capabilities, it is an ideal candidate for custom applications.

### APPLICATIONS

- ▶ Independently controllable angles of incidence and collection for studying bi-directional diffuse reflectance.
- ▶ Motorized for automated changes in the incident angle.
- ▶ Reoriented for vertical sampling to accommodate electrochemical cells and cold fingers.

### SUGGESTED FEATURES

- ▶ Multi-purpose, variable angle reflection accessory.
- ▶ ATR, specular (external), and in-line diffuse reflectance capabilities.
- ▶ Continuously variable angle of incidence, from 5° to 85°.
- ▶ Focuses the incident FT-IR beam on the same area of the sample for all incident angles.
- ▶ Direct angular read-out for all measurements.
- ▶ Maintains polarization for incident angles.
- ▶ PermaPurge™ permits changes in angle without interrupting the purge of the FT-IR system.
- ▶ ATR kits available with ZnSe or Ge hemispherical crystals.
- ▶ Ming-Sung™ ATR Rotator for spectroscopy studies of oriented polymers available.
- ▶ Convenient ATR flow cells, troughs, powder, and heatable stages available.
- ▶ Compatible polarizers offered.
- ▶ Readily mounts in the specified spectrometer.

### SAMPLE APPLICATIONS

- ▶ Thomas Lummerstorfer and Helmuth Hoffmann, "IR Reflection Spectra of Monolayer Films Sandwiched between Two High Refractive Index Material", *Langmuir*, 20(16), 6542 (2004).
- ▶ Thomas Lummerstorfer, Christian Sohar, GernotFriedbacher, and Helmuth Hoffmann, "In Situ Observation of Interfacial Bonding of an Organic Monolayer Confined between Two Solid Surfaces," *Langmuir*, 22(1), 18 (2006).
- ▶ Ross C. Thomas, Andreas Hierlemann, Alan W. Staton, Mark Hill, and Antonio J. Ricco, "Reflectance Infrared Spectroscopy on Operating Surface Acoustic Wave Chemical Sensors during Exposure to Gas-Phase Analytes," *Anal. Chem.*, 71(16), 3615(1999).
- ▶ Dominik Enders, Tadaaki Nagao, Tomonobu Nakayama, and Masakazu Aono, "In situ Surface-Enhanced Infrared Absorption Spectroscopy for the Analysis of the Adsorption and Desorption Process of Au Nanoparticles on the SiO<sub>2</sub>/Si Surface," *Langmuir*, 23 (11), pp 6119 (2007).

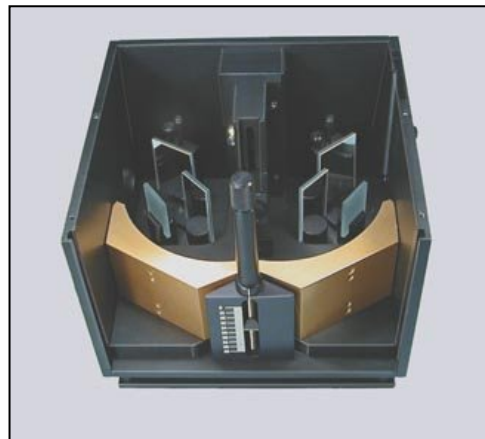

## Twin Parallel Mirror Reflection Accessory Vertical Multiple Reflection ATR

Harrick Scientific can provide a vertical, multiple internal reflection accessory for analysis of solids, powders and liquids. The vertical sample orientation minimizes spectral contamination of liquids from particulates.

### APPLICATIONS

- ▶ Multiple internal reflection spectroscopy.
- ▶ Useful for examining soft surface solids, pastes, liquids and powders by FT-IR.

### SUGGESTED FEATURES

- ▶ Continuously variable angle (30° to 60°).
- ▶ Typically uses 50x10x3mm SPP ATR crystals.
- ▶ Specially designed pressure plates float, eliminating unnecessary strain on the crystal.
- ▶ Flow-through and temperature controlled liquid cells.
- ▶ Base plate or slide plate mounting available.
- ▶ Tsung-type ATR crystals available on special order.



### SAMPLE APPLICATIONS

- ▶ He Li and Carl P. Tripp, "Detection of *Bacillus globigii* Spores Using a Fourier Transform Infrared-Attenuated Total Reflection Method", *Appl. Spectrosc.*, 62(9), 963 (2008).
- ▶ T.E. Nowlin, D. Foss Smith, Jr., and G. S. Cieloszyk, "Thermal Oxidative Stability of Poly-*p*-Xylylenes", *J. Poly. Sci.*, 18, 2103 (1980).
- ▶ Francis M. Mirabella, Jr., "Quantitative Analysis of Polymers by Attenuated Total Reflectance Fourier-Transform Infrared Spectroscopy: Vinyl Acetate and Methyl Content of Polyethylenes", *J. Poly. Sci.*, 20, 2309 (1982).
- ▶ RivkaMaoz and Jacob Sagiv, "On the Formation and Struction of Self-Assembling Monolayers. I. A Comparative ATR-Wettability Study of Langmuir-Blodgett and Adsorbed Films on Flat Substrates and Glass Beads", *J. Colloid. Interface Sci.*, 100(2), 465 (1984).
- ▶ John G. Van Alsten and Steven R. Lustig, "Polymer Mutual Diffusion Measurements using Infrared ATR Spectroscopy", *Macromol.*, 25, 5069 (1992).
- ▶ Eva Marand and L. Mike Smartt, "ATR Spectroscopic Study of PMMA/PDMS Graft Copolymers Using a Barrier Layer Method", *Appl. Spectros.*, 49(4), 513 (1995).
- ▶ JaroslawDrelich, Asem A. Atia, Madhava R. Yalamanchili, and Jan D. Miller, "Formulation and Wetting Characteristics of Adsorbed Layers of Unsaturated Carboxylic Acids at a Fluorite Surface", *J. Colloid Interface Sci.*, 178, 720 (1996).
- ▶ Y. Q. Lu, M. R. Yalamanchili, and J. D. Miller, "FT-IR Internal Reflection Spectroscopy Using Regular Polygonal Internal Reflection Elements", *Appl. Spectros.*, 52(6), 851 (1998).
- ▶ Patricia L. Lang, Jason Cook, Brenda Fuller Morris, Scott Cullison, Scott Telles, and Timothy Barrett, "Characterization of Historic Papers Using Attenuated Total Reflection Infrared Spectroscopy", *Appl. Spectros.*, 52(5), 713 (1998).
- ▶ Jiaying Chen and Joseph A. Gardella, Jr., "Quantitative ATR FT-IR Analysis of Surface Segregation of Polymer Blends of Polystyrene/Poly(dimethylsiloxane)-co-polystyrene", *Appl. Spectros.*, 52(3), 361 (1998).
- ▶ Mehmet Hancer, Roger P. Sperline, and Jan D. Miller, "Anomalous Dispersion Effects in the IR-ATR Spectroscopy of Water", *Appl. Spectros.*, 54(1), 138 (2000).
- ▶ A. M. Almanza-Workman, S. Raghavan and R. P. Sperline, "In-situ ATR-FTIR Analysis of Surfactant Adsorption onto Silicon from Buffered Hydrofluoric Acid Solutions", *Langmuir*, 16, 3636 (2000).
- ▶ Dion Rivera, Pete E. Poston, Roy H. Uibel and Joel M. Harris, "In Situ Adsorption Studies at Silica/Solution Interfaces by Attenuated Total Internal Reflection Fourier Transform Infrared Spectroscopy: Examination of Adsorption Models in Normal-Phase Liquid Chromotography", *Anal. Chem.*, 72, 1543 (2000).

- ▶ Brian J. Ninness, Doug W. Bousfield, and Carl P. Tripp, "In Situ Infrared Technique for Studying Adsorption onto Particulate Silica Surfaces from Aqueous Solutions", *Appl. Spectros.*, 55, 6 (2001).
- ▶ A. Marcia Almanza-Workman, Sriniraghavan, Pierre Deymier, David J. Monk, and Ray Roop, "Water Dispersible Silanes for Wettability Modification of Polysilicon", *J. Electrochem. Soc.*, 149 (1), H6-H11 (2002).
- ▶ Cuihong Jiang, Haiyan Li, and Carl P. Tripp, "Infrared Method for In Situ Studies of Polymer/Surfactant Adsorption on Silica Powders from Aqueous Solution", *Appl. Spectros.*, 57 (11), 1419 (2003).
- ▶ Christopher J. Gabelich, Kenneth P. Ishida, and Richard M. Bold, "Testing of Drinking Water Treatment Co-Polymers for Compatibility with Polyamide Reverse Osmosis Membranes", *9th World Filtration Congress*, 1 (2004).